

## “Dual-Layer” BSD Blind-Spot | LaneChange Detection System

Ultra-sonic & 77GHz Microwave sensors ALL-In-1

### User Manual & Installation Guide





















"Proprietary & Confidential. Intellectual Property of FleetMaster LLC.  
See back page for full Patent Pending disclosures."

## GENERAL CUSTOMER INFORMATION

Thank you for choosing to purchase our “Dual Layer” vehicle series BSD microwave blind spot detection system products. Our aim is to supply you with the best quality product with the best possible service. For the best operating performance and to avoid any false alarm or function failure, we strongly suggest reading this user manual carefully before installation and use.

### 1. List of Items

No.	Item name	Quantity	Photos
1	Main Control Unit	1	
2	Microwave Sensor	2	
3	Power Cable	1	
4	Ultrasonic Sensor	4	
5	Rubber Sleeve (6 degrees)	4	
6	Rubber Sleeve (10 degrees)	4	
7	Rubber Sleeve (13 degrees)	4	
8	Ultrasonic Sensor Extension Cable(5m)	4	
9	Ultrasonic Sensor Extension Cable(2m)	4	
10	Heat Shrink Tubing	1	
11	Microwave Sensor Harness	2	
12	LED Light	2	
13	LED Light Extension Cable	2	

14	Buzzer	1	
15	23mm Hole saw	1	
16	18.8mm Hole saw	1	
17	User Manual	1	
18	Cable Tie	1	

## 2. Product Specifications:

Numbering	Project	Technical Parameters
1	Working Voltage	DC 9V ~ 36V
2	Working Current	≤ 400mA
3	Detection Speed Range	1km/h ~ 120km/h
4	77GHz sensor Maximum Detection Range	Truck: 0.3m-30m Vehicle: 0.3m-30m Motorcycle: 0.3m-30m Pedestrian: 0.3m-10m
5	Ultrasonic sensor Detection Range	0.2-2.0m
6	Buzzer Alarm Mode	LED + Buzzer Alarm
7	Horizontal Detection Angle	120
8	Working Temperature	-20℃ ~ +70℃
9	Storage Temperature	-30℃ ~ +80℃
10	Water Proof	IP67
11	Sensor Size	87.5 x 67.5 x 49mm

## 3. Installation diagram:

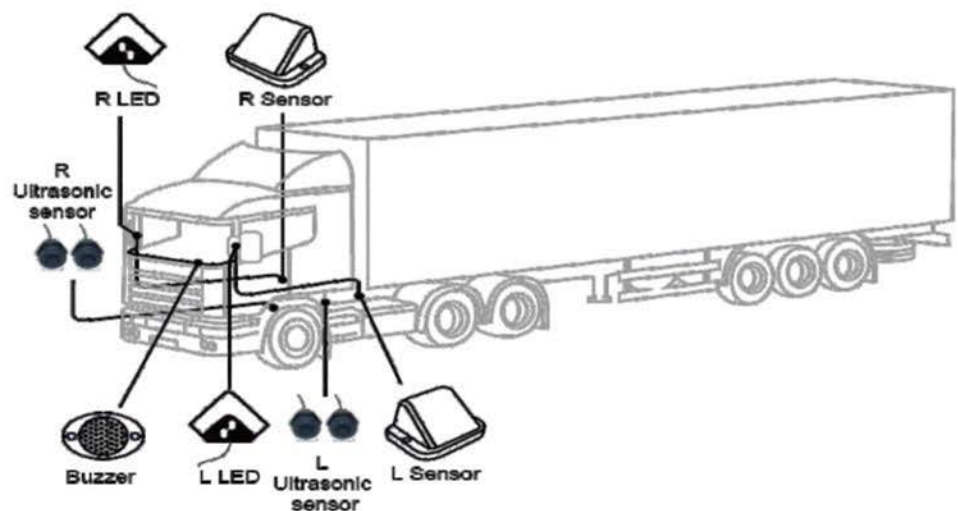

## 4. Wire Connection Diagram

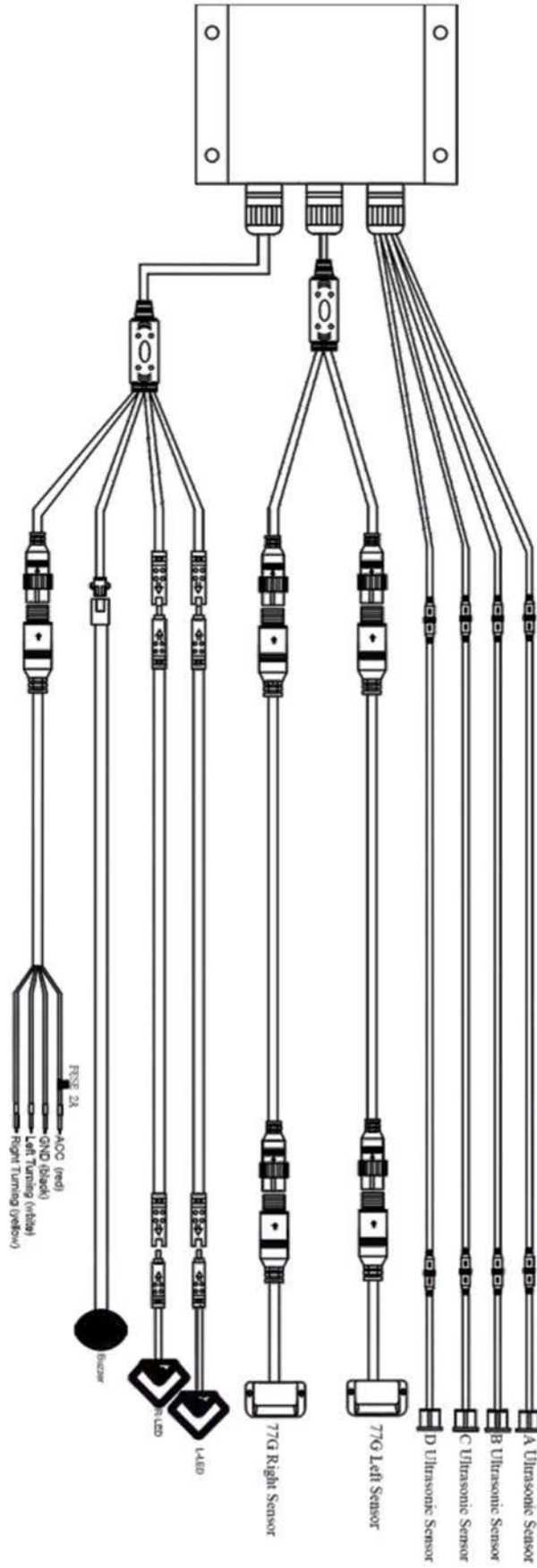

**NOTICE: MANDATORY SAFETY COMPLIANCE & LIMITATION OF LIABILITY**

The FleetVu C93-US4 system is a driver-assistance tool and NOT an automated safety guarantee. Proper system function relies entirely on the operator performing mandatory, daily pre-trip verification. Failure to perform and document these procedures renders the system non-operational and constitutes a material breach of this agreement. **To the maximum extent permitted by applicable law**, the Buyer and their employees agree to **defend**, indemnify, and hold FleetVu harmless against any and all claims, damages, **liabilities, costs, and expenses (including reasonable attorney’s fees)** resulting from operation of the vehicle without strict adherence to these safety protocols.

1. **ULTRASONIC SENSOR VERIFICATION (HAND-VIBRATION TEST)** Prior to every vehicle deployment, the operator must conduct the mandatory manual "Hand-Vibration Test" to confirm individual sensor functionality.

2. **77GHz LANE CHANGE MICROWAVE SENSOR VERIFICATION** The 77GHz microwave sensors are classified as a System-Integrity-Dependent Tool. Verification requires a mandatory two-person procedure:

- A second operator must be positioned inside the cab to confirm visual A-pillar LED activation.
- A first operator must trigger the sensor field externally.
- Verification is only successful when the A-pillar LED activates in response to the external trigger.

3. **DOCUMENTATION & LIABILITY DISCLAIMER** The Buyer assumes sole responsibility for ensuring all operators are trained on these procedures and for maintaining a permanent, daily log of these pre-trip checks. FleetVu assumes no liability for system performance, object detection failure, or vehicle-related incidents should mandatory verification tests not be performed and recorded prior to deployment. Failure to provide such documentation upon request shall void all manufacturer warranties.

**I certify that I have read, understand, and agree to the Safety Protocols and Liability Limitations stated above. I accept full responsibility for ensuring these procedures are implemented for every vehicle deployment.**

Signature / Initials / Date \_\_\_\_\_

**REQUIRED: SIGN AND RETURN TO FLEETVU.** Failure to return this signed acknowledgment will forfeit all FleetVu service obligations and immediately VOID the manufacturer’s warranty.

## 5. Installation guide:

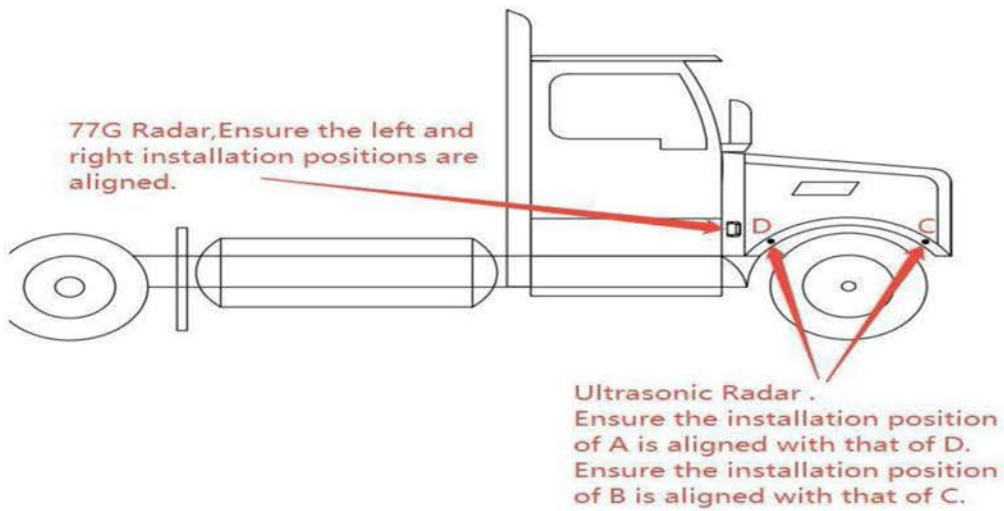
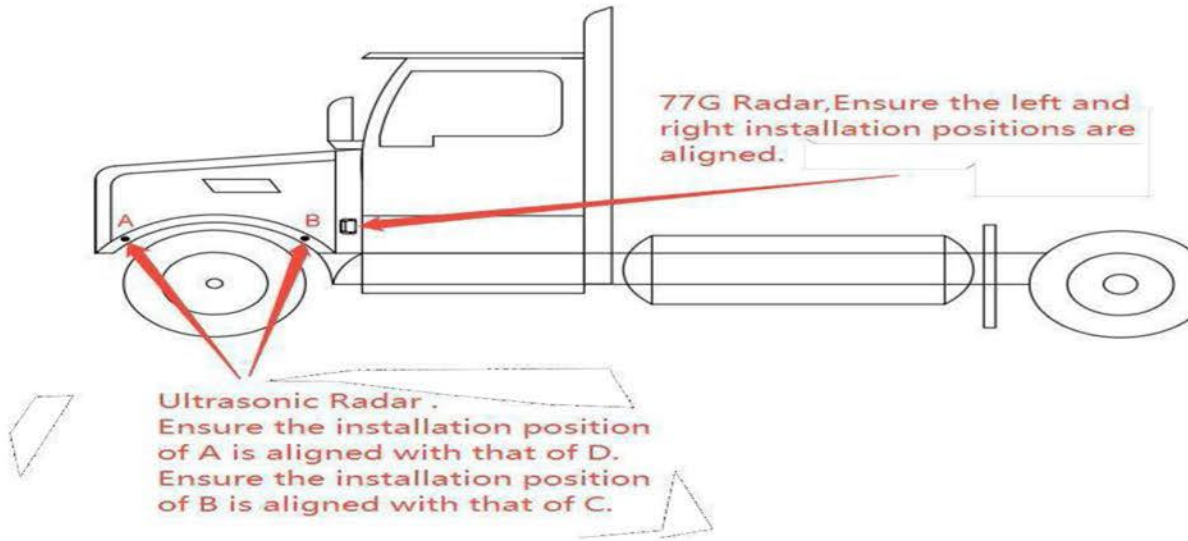

### 5.1 Millimeter Sensors Installation :



Left Millimeter Sensor (above)



Right Millimeter Sensor (above)

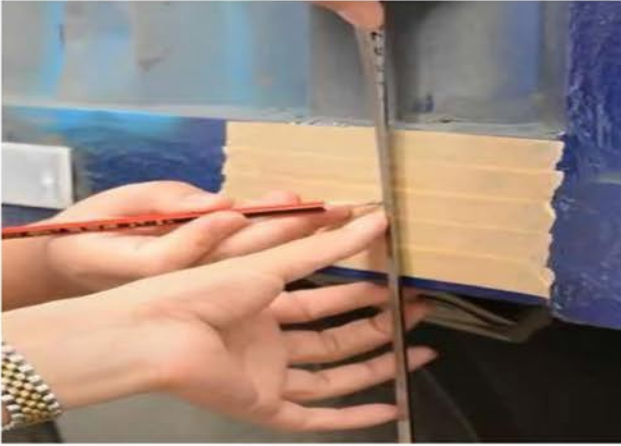

Measure the installation height drill holes



Drilling



Fixing screws



Installation Complete

Note the orientation of the probe installation, with the rear radar bevel facing the rear of the vehicle and the “UP” logo facing up.

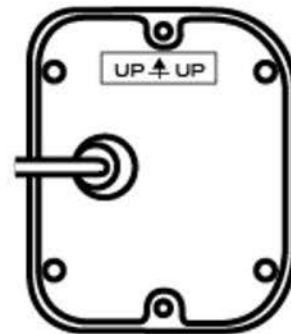

The Millimeter sensor is required to be installed on the side of truck. The height range 80-120cm. 30” to 47” inches. Please note the sensors installation direction. Do not install sensors in the wrong direction, which may produce False positive Alerts.

## 5.2 Ultrasonic sensor installation:



4 Sensors



Installation height



Drilling

The ultrasonic sensors can be mounted on both sides of the vehicle (2 on each fender) above the tires. Or can have 3 on the IE: passenger front fender and 1 on the Bumper as shown) The recommended height is 60-120 cm (23" inches to 47" inches). The distance between the two probes is 40-50 cm. (15" inches to 20" inches). The detection angle of the ultrasonic probe is 60 degrees.

### 5.3 Installation Attention

5.3.1 Remove (Loosen) the Negative Line from the battery before installing.

5.3.2 When removing the connector, do not pull the harness too hard, otherwise it may damage the harness, When the connector is inserted, should be inserted until the real fastening (have a fasten voice)

5.3.3 The wiring fixed in the vehicles wiring harness with the cable ties in the package. So that it does not sag and cut off the excess part of the cable ties.

5.3.4 When disassembly and installation, please follow the requirements of the vehicle maintenance manual to avoid damaging parts. If you accidentally damaged parts, please replace the corresponding parts.

### 5.4 Microwave sensor layout requirements

5.4.1. Microwave sensor (signal emission surface) can only penetrate plastic bumper.

5.4.2. Microwave sensor (signal emission surface) can't have metal in front, of it being it will interfere with proper functioning.

5.4.3. Please do not install microwave sensor (signal emission surface) in front of fluorescent light.

5.5 Following the labels on the wires, connect the ACC, Left Turn Signal, Right Turn Signal, Reverse Light, and GND cables to their corresponding power sources in the vehicle, respectively.

5.6 Route the main harness along the left side to the cab control center, and installation the LED lights and buzzer.

5.6.1 The LED lights installed on A column left and right inside the vehicle.

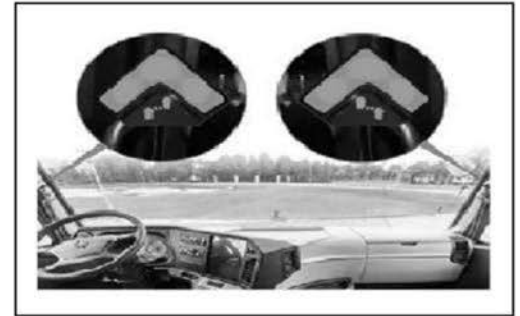

5.6.2 The buzzer's installation location can be customized based on your visual preferences. The location is for reference. Other wiring can refer the installation of the overall diagram, routine installation. customized based on your visual preferences. The location is for reference.



Other wiring can refer the installation of the overall diagram, routine installation.

## 6. Function

6.1 This product is equipped with two, millimeter-wave radars and four ultrasonic sensors. Utilizing dual-technology fusion, it achieves comprehensive blind spot coverage for vehicles. Through installing 2pcs of special 77GHZ microwave sensors on the vehicle side, when the vehicle is moving, if any moving object closed to blind area (3 meters each from right and left side, 30 meters from behind) the object will be detected by system sensors. By installing four

ultrasonic sensors 2 on the left and 2 on the right sides of the front fenders of the vehicle, it can effectively alarm for objects approaching within the blind spot. The LED indicators will turn on to remind the driver, in this condition. If the driver engages directions and changes lanes, the buzzer will make a bi-bi sound to remind the driver.

6.2 Function Introduction:

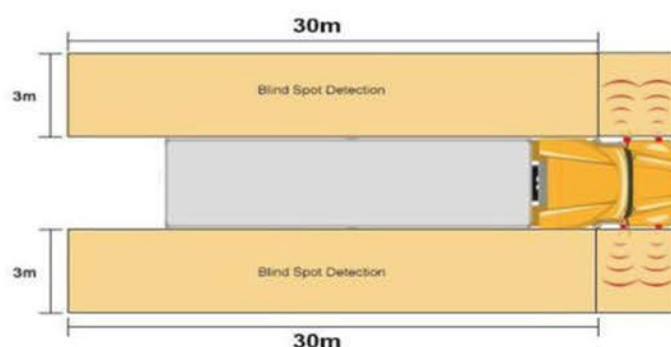

## 6.3 Alert condition:

When the system is on and functioning, the system is designed to detect the following events:

6.3.1. Blind spots while driving: objects in the blind spot areas around your vehicle - in the lanes on the left /right and directly behind the vehicle at a distance of up to 60 ft (approximately 30m).When you're driving straight and not using your turn signal, if a vehicle traveling faster than you in the adjacent lane enters your blind spot, the LED light in the corresponding rearview mirror will illuminate continuously. This light will only turn off when the vehicle leaves your blind spot. When you actively signal your turn, if a faster vehicle enters your blind spot, the LED light in the side mirror will flash and a buzzer will sound. This warning will also cease once the vehicle leaves your blind spot.

6.3.2. Blind spots while being passed /overtaken: When vehicles are approaching/overtaking your vehicle from behind. When the vehicle is driving, if the speed is greater than the target overtaking speed, the target vehicle enters the alarm range, and the LED on the corresponding side is always on until the target vehicle leaves the alarm area and the warning is canceled;

When the speed is greater than the target overtaking speed, the target vehicle enters the monitoring range, the turn signal on the corresponding side is turned on, the LED on the corresponding side flashes, and the buzzer alarms until the target vehicle leaves the alarm area and the warning is canceled

6.3.4 Same-speed alarm (blind spot hold): When the host vehicle is slightly ahead of a target vehicle that is stationary in the host vehicle's blind spot and both vehicles are traveling at the same speed, the LED warning light will illuminate continuously. This continuous warning will remain in effect until the target vehicle exits the blind spot warning area, at which point the warning will be canceled.

## 6.4 Engaging the System:

6.4.1 When the system is turned on each time, the system starts the self-test function, the LED indicators will flashes 2 times, and the buzzer will alarm one time , then the system goes into standby operation.

6.4.2 When the vehicle is driving forward normal, If the ultrasonic sensor detects an object near the front of the vehicle, the LED will be “Green”. If the object is detected by the millimeter-wave radar, the LED will be “Red”. If both sensors are engaged, the LED will be “Yellow”. When normal driving, if there is another vehicle closing to the left or right side of the vehicle, the left or right LED light will light. No buzzer alarm.

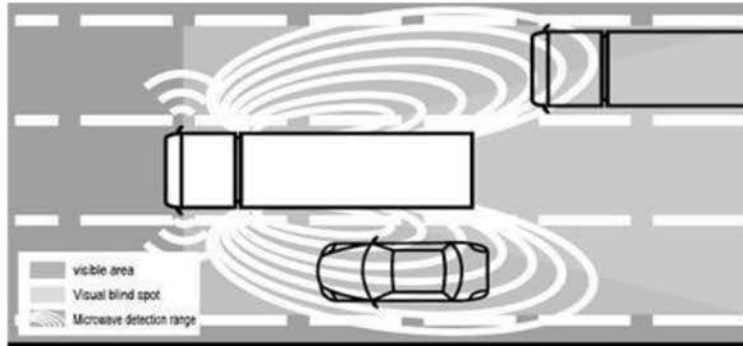

6.4.3 When engaging the Left directional, if there is another vehicle or person closing to the left side of the vehicle, the left LED light will flash and the buzzer will alarm.

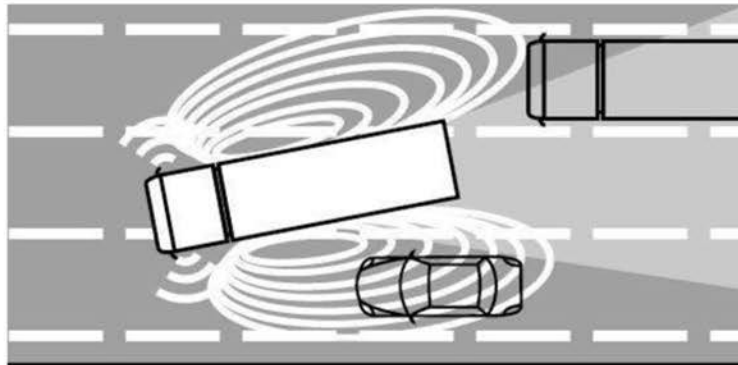

6.4.4 When turning on the Right directional, if there another vehicle closing to the Right side of the vehicle, the Right LED light and buzzer will continue to flash, and buzz.

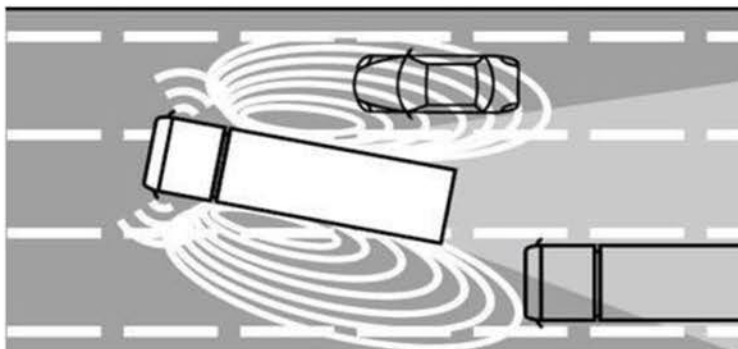

## 7. System Debugging

### 7.1 Vehicle parts recovery

## 7.1 1. Confirm the installation status

- (1) Before powering on, make sure the wiring and installation are normal..
- (2) Perform a special inspection of the vehicle wiring harness. Check that it has not been improperly pressed, stretched, pinched, or otherwise damaged during installation.

## 7.1.2. Power up

- (1) Connect the battery negative terminal (-) to ensure that the vehicle function to work properly.
- (2) If an abnormal occurrence, check the harness installed whether correct.

## 7.2 Test

7.2.1. Starting the truck engine, after ACC power on, the LED lights Yellow color which installed on the left and right side on the truck A column will always engage for 2 seconds at the same time. Also the buzzer will alarm once, that means the system check has been completed. Then system will enter into the environment adaptation test immediately. 5-8 seconds to enter the working state.

7.2.2 Please see 6.4 **Engaging the System** to check the system is OK and 100% functional.

7.2.3 After verifying all the functions, recovery all the parts disassembled during installation on and in the vehicle, bumpers etc.

## 8. Notice:

8.1 In the following situation, the microwave sensor may not be able to detect the target object or it is difficult to detect the target object.

The vehicle is located at the rear blind area of the adjacent lane, but the vehicle is not near.

The vehicle travels next to your car for a long time at almost the same speed.

The vehicle travels from the opposite side.

Vehicles of adjacent lanes try to overtake you.

The adjacent lanes of the vehicle are extremely wide. The detection area of the radar sensor is set to the expressway width of road.

The system alarm lights and warning sounds may not be activated or may be delayed in the following cases.

- When the vehicle is changed from two lanes outside to adjacent lanes
- When driving on steep slopes
- Through the hills or mountain vertex
- Turning radius is small (sharp turn at the crossroad)
- There is a height difference between the driving lane and the adjacent lane.

8.2 If the width of the road is narrow, which may detect two lanes of vehicles.

## 9. General Troubleshooting

No.	Project	Reason	Solution
1	Not flashing	The harness interface is loose or haven't connected	Checking all the harness and make sure all connected
		LED damaged	Replace the LED Lights
2	The left and right LED alarming are opposite	The left and right lights line are wrong connected with the BSD main harness.	Swap left LED line and right LED line to connect the BSD main harness.
3	The buzzer does not alarm	The harness interface is loose or haven't connected	Checking all the harness and make sure all connected
		Buzzer LED damaged	Replace the buzzer

## 10. Statement:

This product is only an auxillary driver assist and lane changing solution. While in actual use, the driver must be strictly in accordance with traffic regulations. Any driving incident or accident that may occur while using this Auxilliary sensor solution, the manufacturer and/or Reseller is not responsible.

### LEGAL NOTICE: PATENT PENDING & PROPRIETARY TECHNOLOGY:

The FleetVu Dual-Layer Advanced Sensor System, including its proprietary Source-Specific Tri-State Logic (\$Red/Green/Yellow\$ alert protocols), 77GHz Square-Profile Radar Integration, and Spatial Mounting Blind-spot configurations (including Fender Well Arch applications), is the subject of pending patent applications with the United States Patent and Trademark Office (USPTO) and protected under international intellectual property laws.

This document and the technology described herein constitute Trade Secrets and confidential intellectual property of FleetMaster LLC. Unauthorized reproduction, distribution, reverse engineering, or derivation of this logic, hardware configuration, or intervention method is strictly prohibited. FleetMaster LLC aggressively enforces its intellectual property rights; violations may result in severe civil and criminal penalties under the Defend Trade Secrets Act (DTSA) and applicable federal and international statutes.

For current IP status and updates, visit: [fleetvu.org](http://fleetvu.org)





## 1. Limited Warranty:

FleetMaster / FleetVu products are warranted against material defects for a period of one (1) year from the date of purchase. FleetVu warrants to the original customer of record / purchaser of the device, that should the product or any part thereof, during normal consumer usage conditions, be defective in material or workmanship that result in product failure within the first twelve (12) month period from the date of purchase, such defects will be repaired or replaced, with a refurbished or new product at the Company's discretion, without charge for parts and labor directly related to the defect(s). This warranty extends to consumers who purchase the product in the United States, Canada and Mexico and it is not transferable or assignable. This warranty does not apply to: a) Products / devices subject to abnormal use or condition, accident, misleading, neglect, unauthorized alterations, misuse, improper installation or repair or improper storage; b) Products whose mechanical serial number or electronics serial number have been removed, altered, or defaced; c) Damage from exposure to moisture, humidity, excessive temperature or extreme environmental conditions; d) Damage resulting from connection to, or use of any accessory or other product not approved or authorized by the Company; e) Defects in appearance, cosmetic, decorative or structural items such as framing and non-operative parts; f) Damage from external causes such as fire, flooding, dirt, sand, weather conditions, battery leakage, a blown fuse, theft or improper usage of any electrical source.

Extended One-Two Year Warranty: FleetVu does offer an optional One or Two Year Warranty at time of purchase. Extended warranties are paid on an additional monthly fee or on an annual payment basis at time of purchase.

Please contact your FleetMaster/FleetVu representative to learn more. 619-684-1181